

HONDA GROM (FLIP OVER FOR KAWASAKI Z125)



45-0305FR
Installation Instructions
Front/Rear Axle Slider Kit

NOTE: Both the front and rear axle kits for this motorcycle are the same.

This kit contains all the parts for one axle. To equip both axles, you should purchase two kits.

- 1) Remove the stock axle from the motorcycle.
- 2) Slide OEM axle through the 45-0305FA base.

NOTE: On the Honda Grom the OEM washers and supplied 12mm washer are not re-used in this kit (Z125 Only).

The axle slider bases replace the OEM washers. Install the OEM axle back through the forks (or the swingarm) and the wheel.

- 3) Slide the other 45-0305FA base over the threaded end of the axle and then install the OEM axle nut. Tighten the axle to factory OEM specification.

- 4) Install the plastic slider puck on the base and secure it using the FH 6mm bolt. The far side of the puck is undersized to help act as a locking mechanism for the bolt.

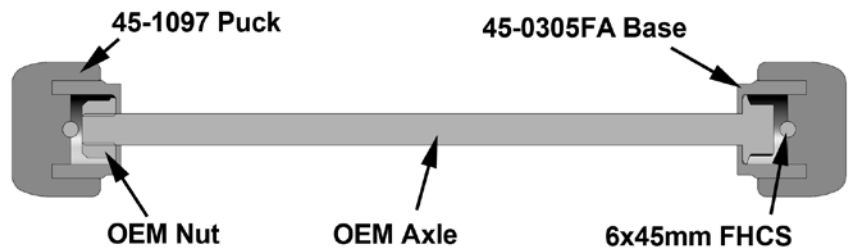

105 Baldwinville Rd, Winchendon, MA 01475

978-297-2977

WARNING: Improper installation and/or failure to comply with all warnings and instructions may cause a loss of control and serious injury or death. The motorcycle should be run and thoroughly inspected before use. DO NOT INSTALL OR USE THIS PRODUCT IF YOU ARE UNABLE TO DO SO IN COMPLIANCE WITH ALL INSTRUCTIONS AND WARNINGS. ALWAYS SEEK THE ASSISTANCE OF A TRAINED PROFESSIONAL TECHNICIAN.

KAWASAKI Z125 (FLIP OVER FOR HONDA GROM)

WOODGRAFT

Technologies, Inc.

45-0305FR
Installation Instructions
Front/Rear Axle Slider Kit

NOTE: Both the front and rear axle kits for this motorcycle are the same.

This kit contains all the parts for one axle. To equip both axles, you should purchase two kits.

- 1) Remove the stock axle from the motorcycle. (**You do not need to reuse the front or rear cotter pins because the bike is equipped with lock nuts**).
- 2) Slide OEM axle through the 45-0305FA base. Install the OEM axle back through the forks (or the swingarm) and the wheel.
- 3) Slide the 04-WA12Z washer and the other 45-0305FA base over the threaded end of the axle and then install the OEM axle nut. (**You will need to retain the OEM chain adjuster, pictured below, to ensure proper fitment of the rear axle slider**). Tighten the axle to factory OEM specification.

- 4) Install the plastic slider puck on the base and secure it using the FH 6mm bolt. The far side of the puck is undersized to help act as a locking mechanism for the bolt.

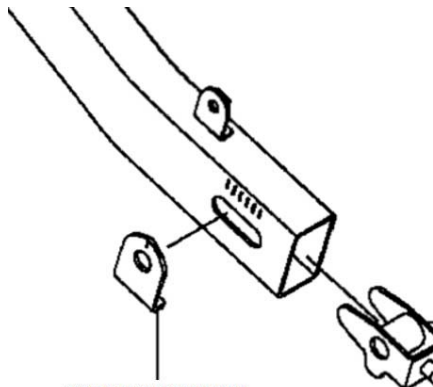

YOU MUST RETAIN THIS
OEM CHAIN ADJUSTER



Z125 Pro Rear Axle w/OEM Chain Adjuster

Z125 Pro Rear Axle w/OEM Chain Adjuster

105 Baldwinville Rd, Winchendon, MA 01475

978-297-2977

WARNING: Improper installation and/or failure to comply with all warnings and instructions may cause a loss of control and serious injury or death. The motorcycle should be run and thoroughly inspected before use. **DO NOT INSTALL OR USE THIS PRODUCT IF YOU ARE UNABLE TO DO SO IN COMPLIANCE WITH ALL INSTRUCTIONS AND WARNINGS. ALWAYS SEEK THE ASSISTANCE OF A TRAINED PROFESSIONAL TECHNICIAN.**