



Yamaha 12-0409AP Clipon Adapter Plate Installation Instructions

WARNING Installation and use of some Woodcraft Technologies, Inc. products will change the response of the motorcycle to rider control inputs. Failure of the rider to adapt to these changes may cause loss of control, and serious injury or death. Improper installation, and/or failure to comply with all warnings and instructions may cause loss of control and serious injury or death. **DO NOT INSTALL OR USE ANY WOODCRAFT TECHNOLOGIES, INC. PRODUCTS IF YOU ARE UNABLE TO DO SO IN COMPLIANCE WITH ALL INSTRUCTIONS AND WARNINGS. SEEK THE ASSISTANCE OF AN EXPERIENCED TECHNICIAN.**

1. Completely remove your stock grips, controls and handlebar assembly. This kit replaces both the stock handlebar and the top clamp of the OEM assembly.
2. Use the supplied mounting bolts to secure the Woodcraft adapter plate to the OEM handlebar base unit.
3. This clamp is designed so that the riser portion of the clamps can point either up or down. Note: some aftermarket fork kits only allow the 1 inch riser to be used in the down position. Larger drops can cause interference with the fork tube. Here are some approximate bar movement examples to help you determine how you would like to install them.

2 inch riser UP	1 inch drop
1 inch riser UP	2 inch drop
1 inch riser DOWN	3 inch drop

NOTE: 10MM spacer required for 1 inch in the down position in order to have proper tank clearance. We do not recommend running the 1.5 inch in the down position with standard bars, as the clearance to the tank is very close. If you do decide to go this route, the 10MM spacer required and you can gain the additional clearance needed by running the extra long bars as this will move the grips away from the tank.

4. (all but 17+ FZ09) The gauge relocation bracket moves the gauges to the center of the bar, which is a position favored by many riders. The relocation bracket is required when using the risers in the UP position, and is optional when using it in the DOWN position. Be sure to put the small aluminum spacers under the OEM gauges when bolting it down.

NOTE: This part is not included for the 17+ FZ09. For this model your gauges stay in the stock location

5. Bolt the riser clamps to the adapter plate using the included bolts. **IMPORTANT: These bolts must have the threads completely coated with blue threadlocking compound before installation.**
6. The OEM controls have anti rotation pins, which require you to drill holes in the handlebars for proper installation. Measure the diameter of the holes in the stock handlebars and select the appropriate drill bit.
7. Secure the bars into the riser clamps. Slide the controls into place, noting that the grips should end right where the plastic end plug meets the aluminum. Mark the location for the anti rotation pins and drill the holes for them. Test the controls to be sure that they are able to be securely tightened and that everything moves freely. Secure the gauges back to the OEM base using the stock hardware.

NOTE: All bolts that secure the riser to the main clamp must be installed with threadlocking compound

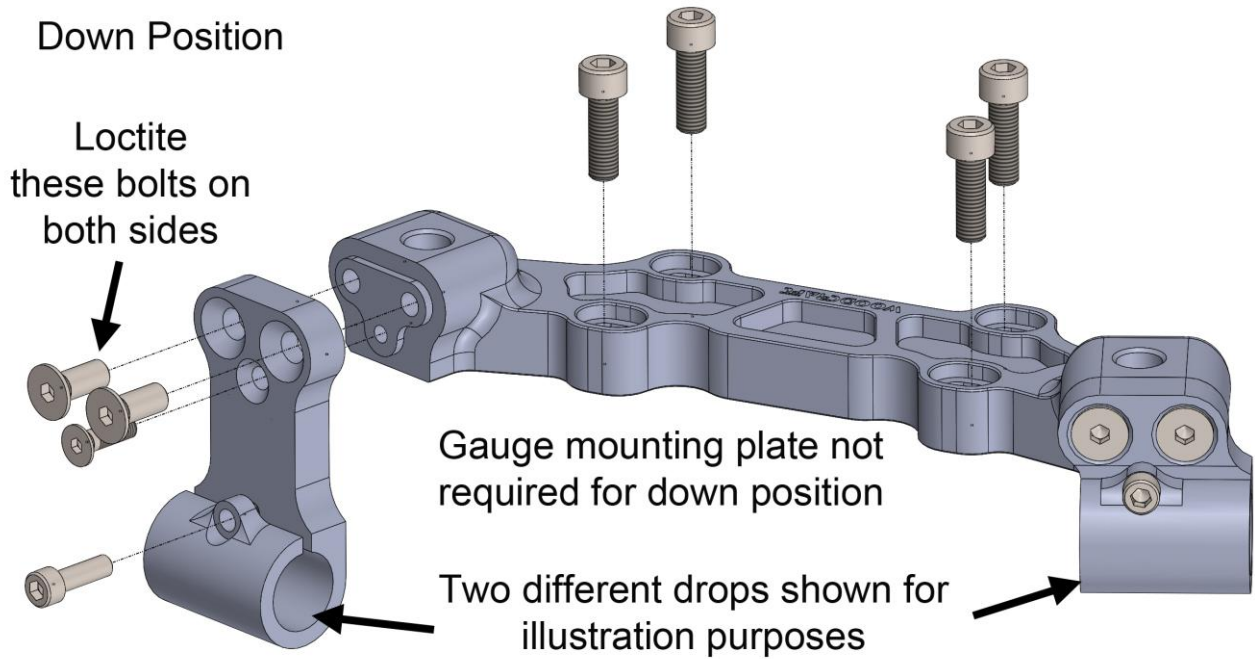
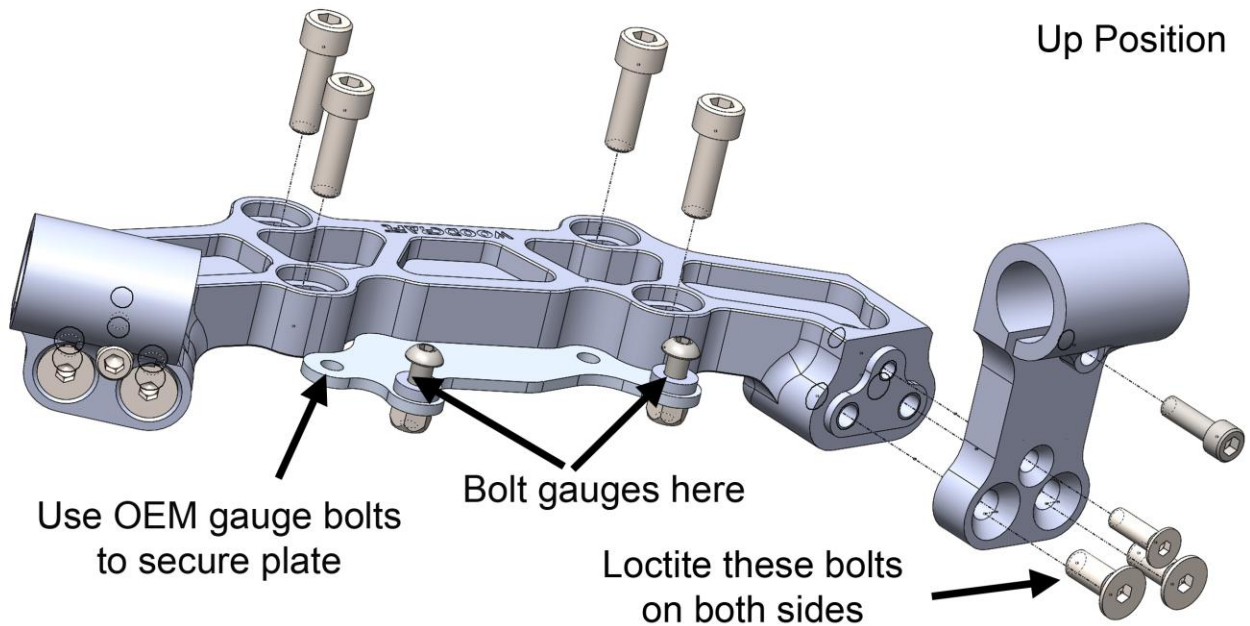

WARNING - VERY IMPORTANT : Ensure that the cables, hoses and all control parts do not contact any part of the motorcycle and that you have full ability to manipulate the controls throughout the entire range of steering. Also, be sure that the throttle returns freely after being fully opened throughout the entire range of steering. **FAILURE TO HEED THESE WARNINGS MAY CAUSE LOSS OF CONTROL OF MOTORCYCLE AND SERIOUS INJURY OR DEATH. DO NOT OPERATE THE MOTORCYCLE IF THERE ARE ANY INTERFERENCE ISSUES WITH EITHER THE MOTORCYCLE PARTS OR YOUR BODY, OR WITH A THROTTLE THAT DOES NOT RETURN FREELY.**