

1) **Axle Side:** The large base 45-0790FA with the expansion slot will be installed in the axle itself. To install the base, thread the 8x30mm socket head bolt into the assembly until it is almost tight, leaving a small gap between the halves. Slide the assembly into the hole of the axle and be sure that it is fully seated against the axle.

**Important Note:** Sometimes axles are damaged when hammered in, and will slightly deform the axle itself. Since our axle sliders are a precise fit, you will need to file off any raised edges. You will not need to do this on an axle in good condition.

2) Tighten the 8mm allen bolt to lock the assembly in place.

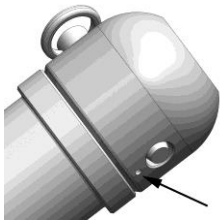

3) Install the plastic top 45-1099 using the removable pin 45-5099.

**Important:** One side of the puck has a small hole drilled beneath the main hole. Install the pin so that the end of the pin with the ball is on the same side as this small hole. The pin should be installed so that the ring is on the top half of the slider.

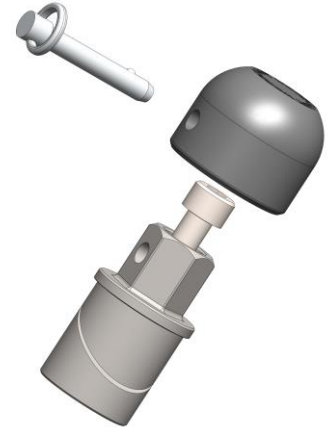

4) **Nut Side:** Remove the stock axle nut. Replace this nut with the base 45-0790FN for the axle slider. Tighten the nut to OEM specifications,

5) Install the plastic top 45-1099 using the removable pin 45-5099. **Important:** One side of the puck has a small hole drilled beneath the main hole. Install the pin so that the end of the pin with the ball is on the same side as this small hole.

A note for racers: If your tech inspector wants you to safety wire these (most will not) then you simply need to orient the pins so that the pull on the pin is both clockwise and down (so that it acts to both tighten the bolt and pull the pin into the puck)

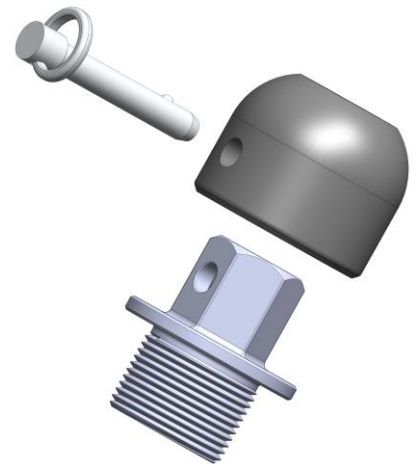

105 Baldwinville Rd, Winchendon, MA 01475

978-297-2977

WARNING: Improper installation and/or failure to comply with all warnings and instructions may cause a loss of control and serious injury or death. The motorcycle should be run and thoroughly inspected before use. DO NOT INSTALL OR USE THIS PRODUCT IF YOU ARE UNABLE TO DO SO IN COMPLIANCE WITH ALL INSTRUCTIONS AND WARNINGS. SEEK THE ASSISTANCE OF A TRAINED PROFESSIONAL TECHNICIAN.